

DW 5000 SERIES HI-HAT STAND

Remove the stand, accessories and all packing materials from the box, then follow these instructions to set-up and adjust your hi-hat to fit the way you play.

Section 1: Assembly

1.1: Base Section (5500TD & 5500TL)

1. Loosen the four keyscrews on the sides of the footboard assembly and unfold the assembly so that the bottom keyscrews fit into the notches on the side panels.
2. Once the pedal is in its horizontal playing position, tighten the keyscrews securely.
3. To more permanently secure the pedal plate to the base casting, line up the holes in the bottom of the base casting with the holes in bottom of the pedal plate. Insert the two screws (provided) through the bottom of the assemblies and tighten the lock washers and nuts from the top.

1.1: Base Section (5500D & 5500L)

1. Fold out the footboard and radius rod assembly and insert the radius rod into the two holes in the base casting so that the heel plate will sit flush with the floor.

1.2: Leg Assembly (all 5000 Hi-Hat models)

1. Loosen the drumkey screw and wingscrew on the leg assembly clamps.
2. Pull the legs out and away from the center tube and place the base section on the floor.
3. Slide the bottom clamp of the leg assembly downward so that it touches the top of the base casting and adjust the spread and height of the legs so that the pedal plate/footboard assembly is flush with the floor (forming a tripod) and the center tube is vertical.

DW's patented dual-leg assembly (5500TD & 5500TL) and three-leg assembly (5500D & 5500L) has been designed to rotate in order to accommodate double bass drum pedals, stands and other set-up requirements. Rotate the leg assembly to its desired position and then tighten the key and wingscrews to secure the position.

1.3 Upper Rod (all 5000 Hi-Hat models)

1. Remove the clutch from the upper rod by loosening the wingscrew and sliding the clutch off the rod.
2. Select either the short or long rod depending on your preference and application and insert the threaded end of the upper rod into the receiver in the lower rod (inside the base section).
3. Screw the two rod sections together by rotating the upper section clockwise until tight.

1.4 Upper Tube Section (all 5000 Hi-Hat models)

1. Loosen the memory lock on the upper tube section and place the upper tube over the upper rod so that the rod comes through the center of the hi-hat cymbal seat and the tube fits into the tube receiver of the lower tube section.
2. With the footboard facing towards you in its normal playing position, rotate the upper tube so that the angle adjustment wingscrew is positioned between the "9:00" and "12:00" position.
3. Adjust the tube height as required and tighten the tube receiver wingnut and memory lock.

Section 2: Mounting and Adjusting the Cymbals

2.1: The Clutch (all 5000 Hi-Hat models)

1. Separate the hi-hat clutch by loosening the drumkey screw, unthreading the bottom nut and removing the lower felt washer.
2. Place the top hi-hat cymbal on the clutch stem so that the top of the bell rests on the top felt washer and replace the bottom felt below the cymbal.
3. Thread the bottom nut back onto the stem until it stops.
4. Adjust the lower of the two knurled nuts at the top of the clutch to achieve the desired space between the cymbal and the felt washers and lock the position by tightening the upper knurled nut against the lower one.
5. Place the bottom hi-hat cymbal on the cymbal seat located at the top of the upper tube so that the upper rod comes through the mounting hole in the cymbal and the bell rests on the cymbal seat felt. Place the clutch/cymbal assembly over the upper rod so that the top cymbal rests on top of the bottom cymbal. Depress the pedal and, when the desired space between the cymbal is achieved, tighten the wingscrew on the clutch.
6. To further secure this position for more intense playing situations, reach between the

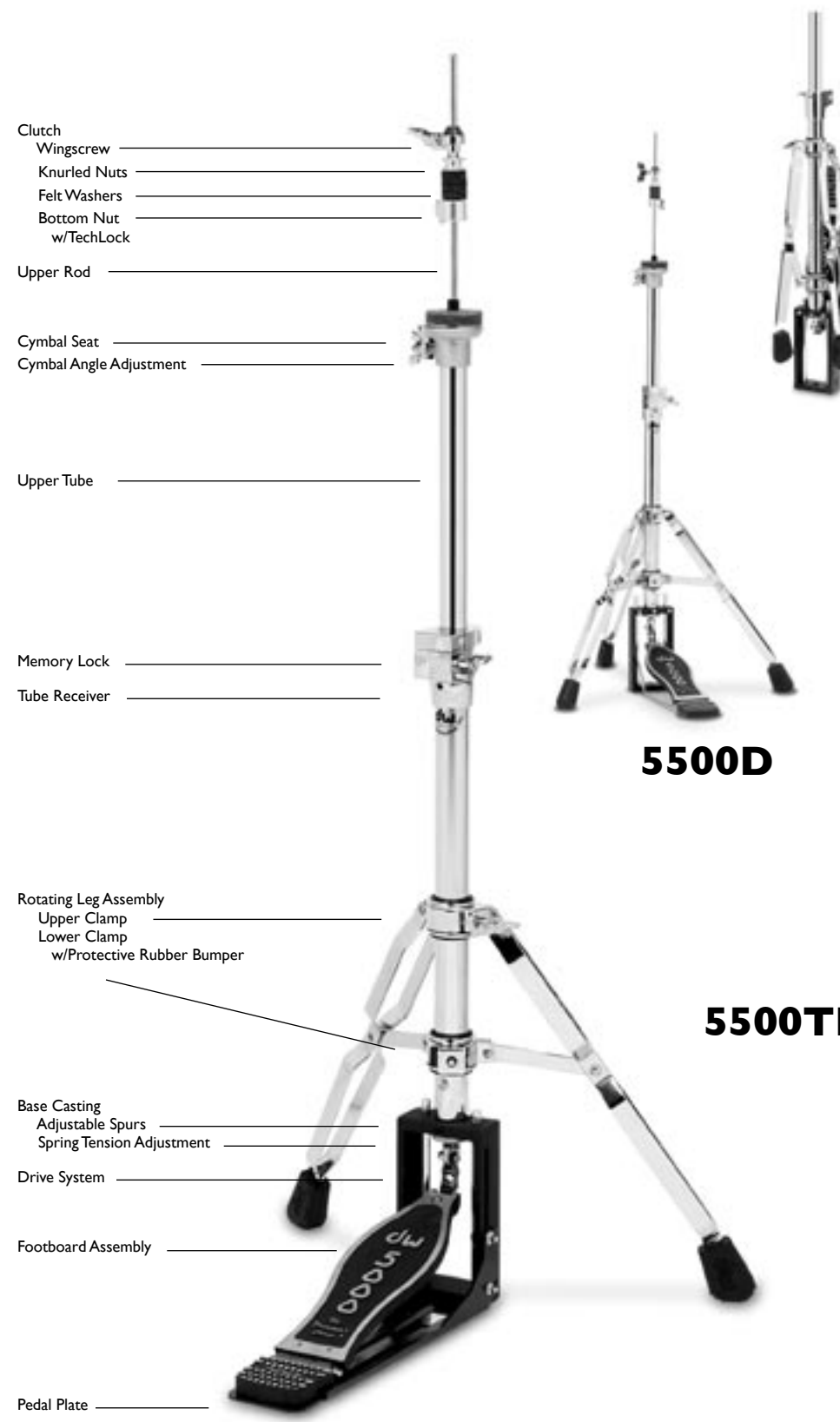

cymbals with a drumkey and tighten the drumkey screw on the clutch.

2.2: Bottom Cymbal Angle Adjustment (all 5000 Hi-Hat models)

The lateral adjustment mechanism at the top of the upper tube is designed to adjust the angle of the bottom hi-hat cymbal and enhance the cymbals' performance and sound quality. To adjust the angle, turn the wingscrew while playing the pedal to achieve the desired sound. Once the optimal position is achieved, tighten the inside nut against the wingscrew to lock the angle/position

2.3: Spring Tension (all 5000 Hi-Hat models)

The 5000 Series Hi-Hats provide for incremental spring tension adjustment. To adjust the feel of the pedal:

1. Loosen the drumkey screw in the center top of the base casting (front side for 5500D & 5500L, back side for 5500TD & 5500TL).
2. Rotate the drumkey screw clockwise to tighten the spring and counter clockwise to loosen it.

Section 3: Adjustable Spurs and Velcro™

Your DW Hi-Hat stand includes built-in, adjustable spurs and non-skid Velcro™ on the bottom of the pedal plate to prevent hi-hat crawl. The Velcro™ automatically grips on most types of carpeting. To adjust the spurs, loosen the keyscrews on the sides of the base casting, lower the spurs to their desired position and tighten the screws. Be careful to use the spurs on carpet/soft surfaces as they may damage some types of flooring.

Section 5: Pack Up

1. Remove the cymbals and clutch.
2. Separate the top tube and rod sections from their bottom counterparts.
3. Fold the leg assembly by loosening the wingscrew in the top clamp and sliding the clamp up the tube to bring the legs inward. Once the legs are folded up, tighten the wingscrew to secure them. You do not have to loosen the keyscrew on the bottom clamp.
4. For 5500TD & 5500TL models, fold-up the footboard assembly by loosening the four keyscrews connecting it to the base casting. Slide the patented folding spring-release footboard upward in the slotted casting to release all tension on the spring. Tighten the top keyscrews to secure the footboard in its transport position. On other models, remove the radius rod from the base casting and fold up the footboard.

Customizing Your Pedal with the DW Hi-Hat Pedal Customizing Kit (part #1236, sold separately, works only for 5500TD & 5500TL models)

Elevator Heel Platform (U.S. Patent No. 6359205)

DW's advanced 9-Position "Elevator" Heel Plates provide a unique method for drummers to achieve a more comfortable pedal playing position without sacrificing speed, power or accuracy. By using different combinations of the heel sections, the height of the heel can be adjusted independently of the angle of the footboard. The "Elevator" positions range from normal (#1) and slightly elevated (#2-3) to raised (#4-7) and extreme (#8-9). Position #8, for example, is recommended for achieving a smoother, more effortless heel-toe sliding technique, while positions #2 and #3 offer a subtle but effective way to increase control.

To install the Elevator heel sections, first turn the pedal over and remove the three screws holding the original heel (A) to the pedal plate. In order to loosen chemical lock holding the three screws, you may first need to heat them with a hair dryer for 2-3 minutes. Place additional Elevator heel sections (B, C) either below or above the original section and re-attach the stacked heel sections using the longer screws (provided). The following chart indicates which screws (supplied) should be used in conjunction with the Elevator heel sections to modify the height of your heel.

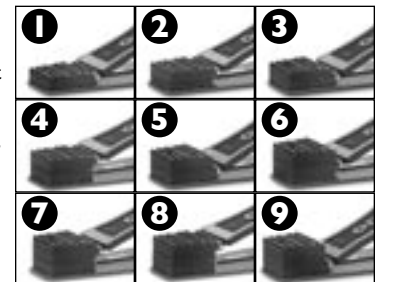

	heel position	heel sections	top screws	bottom screws
	#1	A	3/4"	-
	#2	A/B	3/4"	-
	#3	B/A	7/16"	7/16"
	#4	A/C	-	1 1/4"
	#5	A/C	3/4"	7/16"
	#6	A/C/B	3/4"	3/4"
	#7	B/A/C	7/16"	1 1/4"
	#8	C/B/A	-	1 1/2"
	#9	C/B/A	1 1/4"	7/16"

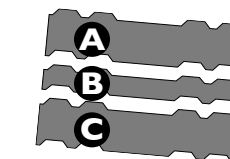

DW 5000 SERIES BASS DRUM PEDAL ACCESSORIES

SM379	Tech-Lock™ Hi-Hat Clutch
SM505	Drop-Lock™ Hi-Hat Clutch
SM803-2	2-Key pack (includes hi-torque and standard keys w/ tube clips)
SM808	5-Key pack (includes standard, large, keychain, drill bit and speed keys)
SM1236	Stacking Heel Kit (includes stacker heels and screws)
SMSVKIT	Drummer's Survival Kit (includes plastic case)



379 505



SMSVKIT



1236



803-2

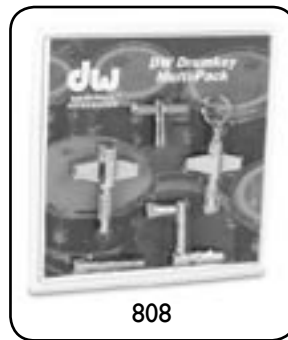

808



Contact your authorized DW dealer for additional accessories and replacement parts.

5500TD, 5500TL, 5500D, 5500L HI-Hat Stand

DW 5000 SERIES HI-HAT STAND

OWNER'S MANUAL



Thanks for purchasing this DW product. It has been designed and manufactured to provide a lifetime of trouble-free service. Please take a moment to familiarize yourself with the exclusive features and operating suggestions contained in this manual in order to ensure its optimum performance. Should you have any further questions, feel free to contact your local authorized DW dealer.

— Don Lombardi
president, Drum Workshop, Inc.



The Drummer's Choice®

DRUM WORKSHOP, INC
3450 Lunar Court • Oxnard, CA 93030 USA
www.dwdrums.com

specifications subject to change without notice
PR-OM-5500 © DW 2004

**DW PEDALS
5-YEAR LIMITED WARRANTY**

For a period of five years from the date of purchase, Drum Workshop, Inc. guarantees the original owner, when presented with proof of purchase, that all 9000, 5000 and 7000 Series Bass Drum Pedal cast parts are free of material and manufacturing defects. This warranty is limited to cast parts only; such as the base casting, footboard, beater hub, sprocket, heel and cam casting. This warranty does not include moving parts; such as the spring assembly, beater ball, radius rod, hex shaft, ball bearings, etc. If under normal playing conditions parts covered in this limited five year warranty fail, they will be replaced at no charge. Return the pedal to your authorized DW dealer or, if there is not a dealer in your area, contact DW directly. DO NOT send pedal to DW without first receiving a Return Authorization Number. Shipping charges to DW will be paid by the consumer. DW's maximum liability pursuant to this warranty is limited to the monetary value of the product that is the subject of the warranty claim. This is a summary only; please see the actual limited warranty for additional terms and conditions.